

FNAME: IS-WD3P-4-302X
REVDATE: 1117

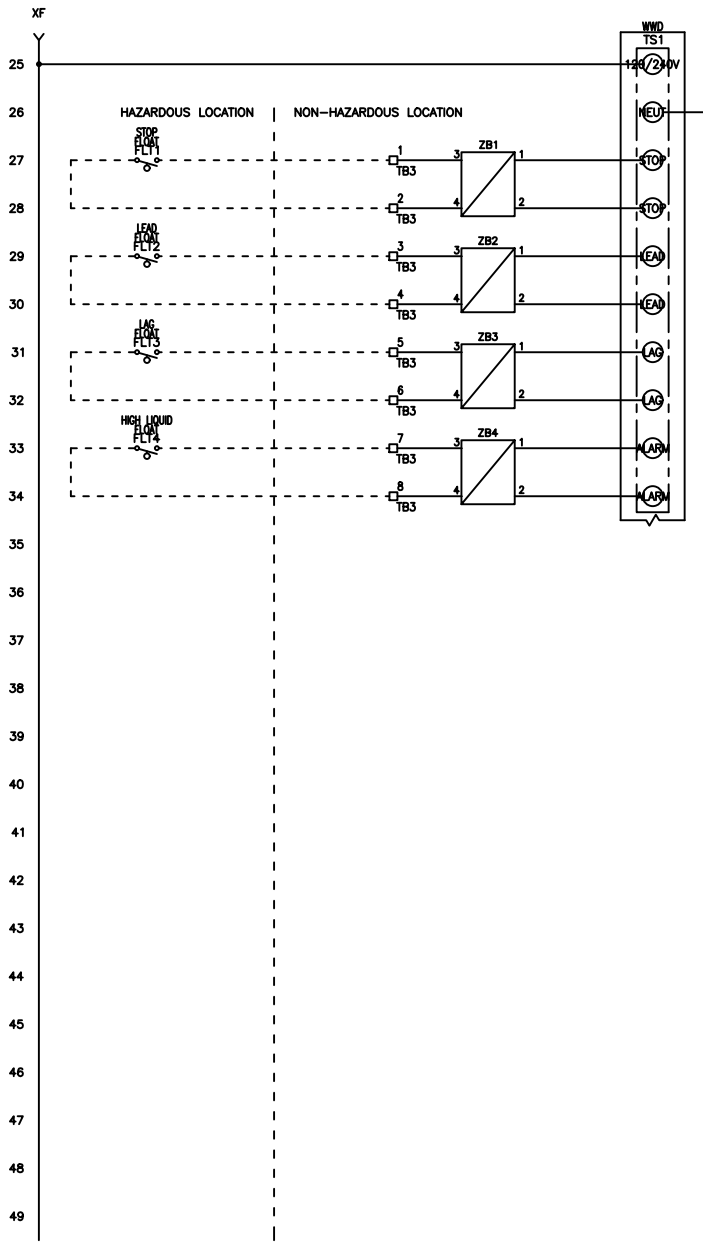
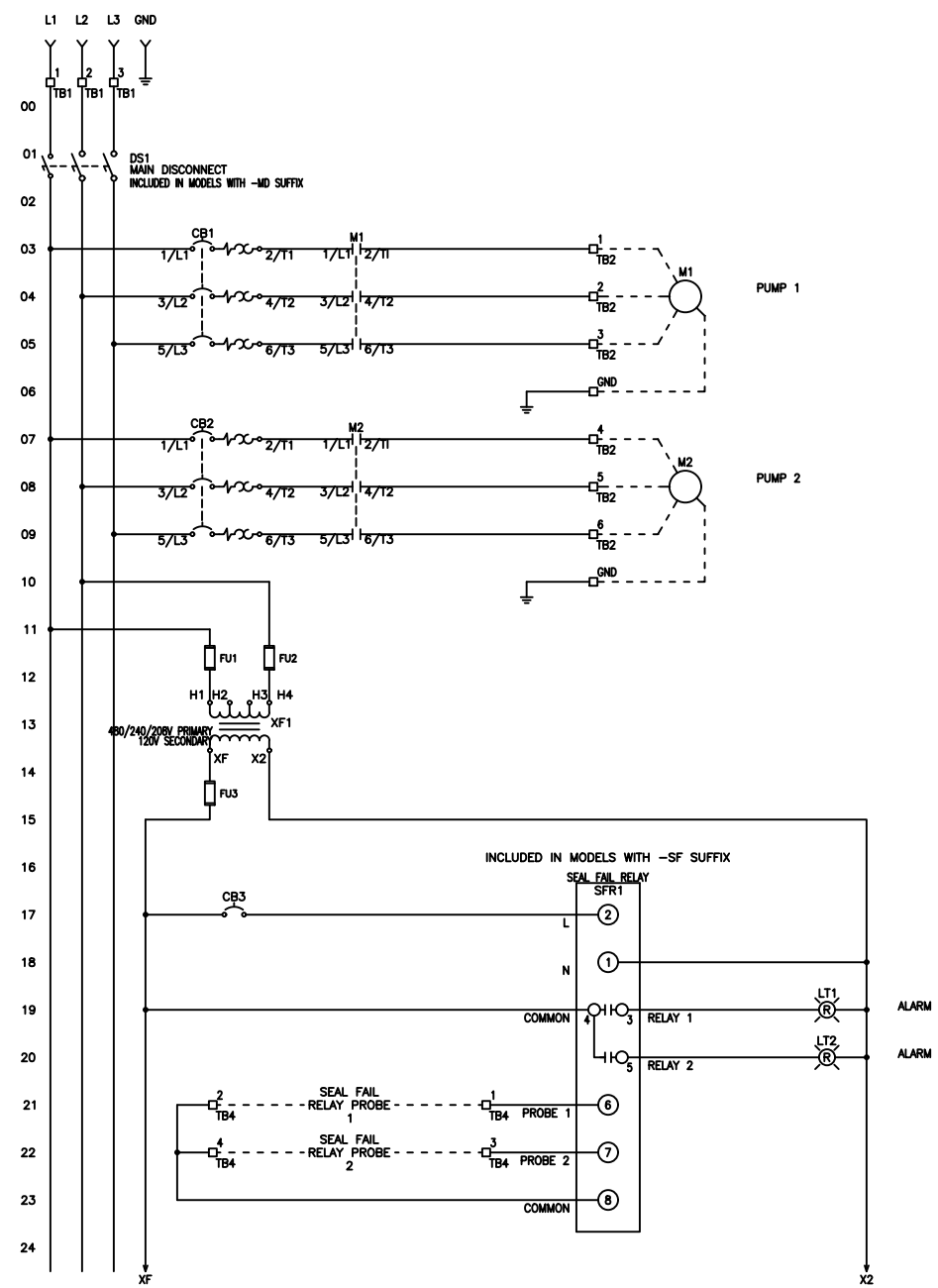

REVISIONS				
ZONE	REV	DESCRIPTION	DATE	APPROVED
	A	ADDITION OF OPTIONAL SEAL FAIL RELAY	1/17/15	
	B	UPDATED INSTRUCTIONS	5/25/17	
	C	REVISED CBS	9/21/17	
	D	UPDATED TERMINAL BLOCKS	11/13/17	
	E	UPDATED SEAL FAIL RELAY	2/28/18	
X2	F	Transformer Label X1 to XF	4/29/19	

MULTITAP TRANSFORMER INSTRUCTIONS:

CONNECT FACTORY TAGGED WIRES TO APPROPRIATE TRANSFORMER VOLTAGE TAP. SEE BELOW FOR CONNECTIONS:

FOR 208V OPERATION, CONNECT TO FUSE INPUT HF & TO TRANSFORMER TAP H2

FOR 240V OPERATION, CONNECT TO FUSE INPUT HF & TO TRANSFORMER TAP H3

FOR 480V OPERATION, CONNECT TO FUSE INPUT HF & TO TRANSFORMER TAP H4

----- DASHED LINE INDICATES FIELD WIRING.

USE COPPER CONDUCTORS ONLY.

TEMPERATURE RATING OF CONDUCTORS IS TO BE 60°C (167°F).

BRANCH CIRCUIT PROTECTION SHALL BE PROVIDED BY THE INSTALLER. MUST BE SIZED ACCORDING TO PUMP/MOTOR MANUFACTURING SPECIFICATIONS.

VERIFY CORRECT OPERATION OF CONTROL PANEL AFTER INSTALLATION IS COMPLETE.

DRAWN BY: KJ
DATE: 1/8/15

APPROVED BY: _____
DATE: _____



THIS DRAWING CONTAINS PROPRIETARY INFORMATION AND SHALL NOT BE USED OR DISCLOSED WITHOUT PRIOR WRITTEN AUTHORIZATION.

TITLE: IS-WD3P-4-302X CONTROL SCHEMATIC			
SIZE: B	DWG NO.: 1534	PART NO.: IS-WD3P-4-302X	REV: F
SCALE: NONE	SHEET: 1 OF 3		

FRAME: IS-WD3P-4-302X

REVDATE: 1117

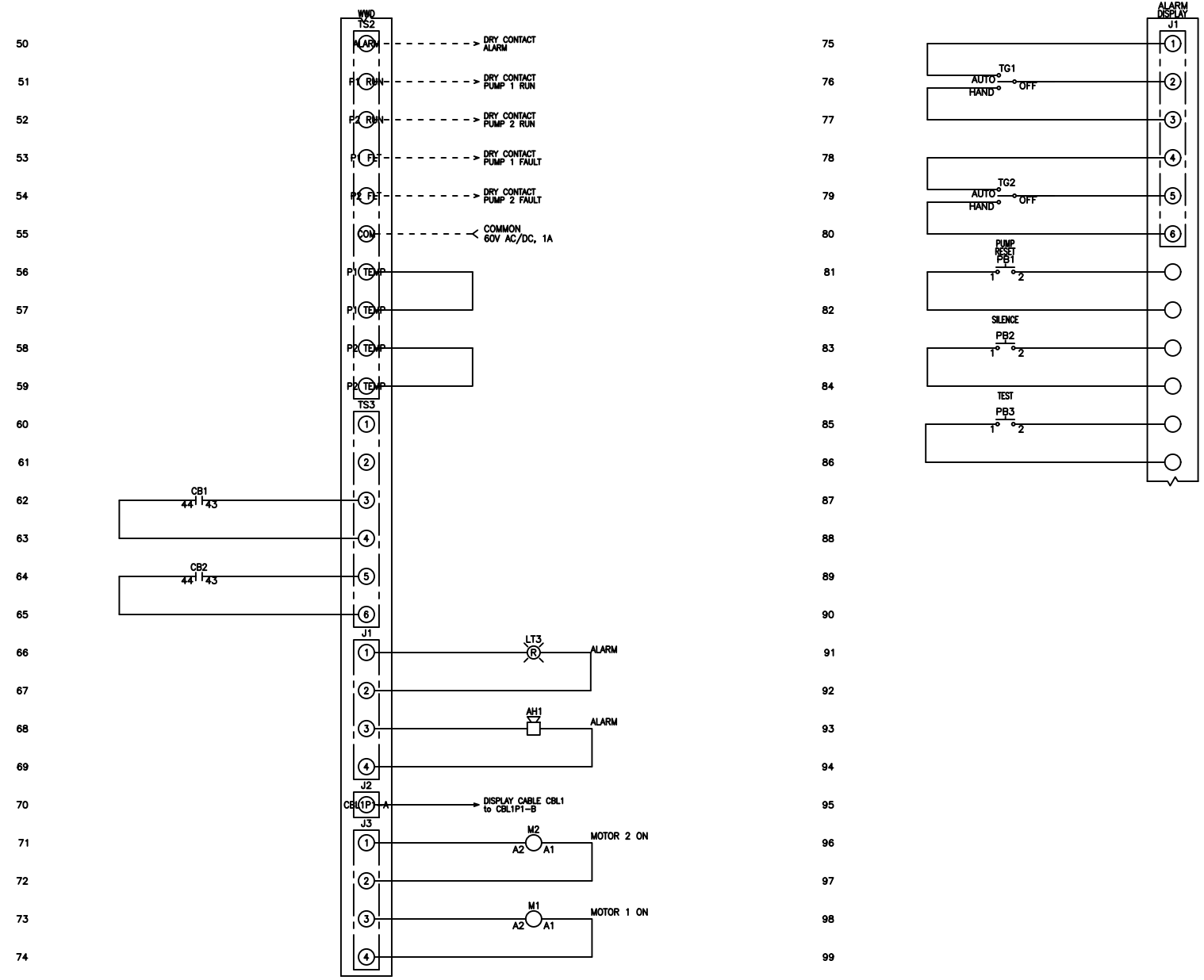

REVISIONS				
ZONE	REV	DESCRIPTION	DATE	APPROVED
	A	ADDITION OF OPTIONAL SEAL FAIL RELAY	1/17/15	
	B	UPDATED INSTRUCTIONS	5/25/17	
	C	REVISED CBS	9/21/17	
	D	UPDATED TERMINAL BLOCKS	11/13/17	
	E	UPDATED SEAL FAIL RELAY	2/28/18	
	F	Transformer Label X1 to XF	4/29/19	

MULTITAP TRANSFORMER INSTRUCTIONS:

CONNECT FACTORY TAGGED WIRES TO APPROPRIATE TRANSFORMER VOLTAGE TAP. SEE BELOW FOR CONNECTIONS:

FOR 208V OPERATION, CONNECT TO FUSE INPUT HF & TO TRANSFORMER TAP H2

FOR 240V OPERATION, CONNECT TO FUSE INPUT HF & TO TRANSFORMER TAP H3

FOR 480V OPERATION, CONNECT TO FUSE INPUT HF & TO TRANSFORMER TAP H4

----- DASHED LINE INDICATES FIELD WIRING.

USE COPPER CONDUCTORS ONLY.

TEMPERATURE RATING OF CONDUCTORS IS TO BE 60°C (167°F).

BRANCH CIRCUIT PROTECTION SHALL BE PROVIDED BY THE INSTALLER. MUST BE SIZED ACCORDING TO PUMP/MOTOR MANUFACTURING SPECIFICATIONS.

VERIFY CORRECT OPERATION OF CONTROL PANEL AFTER INSTALLATION IS COMPLETE.

DRAWN BY: KJ	DATE: 1/8/15				
APPROVED BY:	DATE:				
THIS DRAWING CONTAINS PROPRIETARY INFORMATION AND SHALL NOT BE USED OR DISCLOSED WITHOUT PRIOR WRITTEN AUTHORIZATION.		TITLE: IS-WD3P-4-302X CONTROL SCHEMATIC			
		SIZE B	DWG NO. 1534	PART NO. IS-WD3P-4-302X	REV F
		SCALE NONE		SHEET 2 OF 3	

FNAME: IS-WD3P-4-302X

REVDATE: 1117

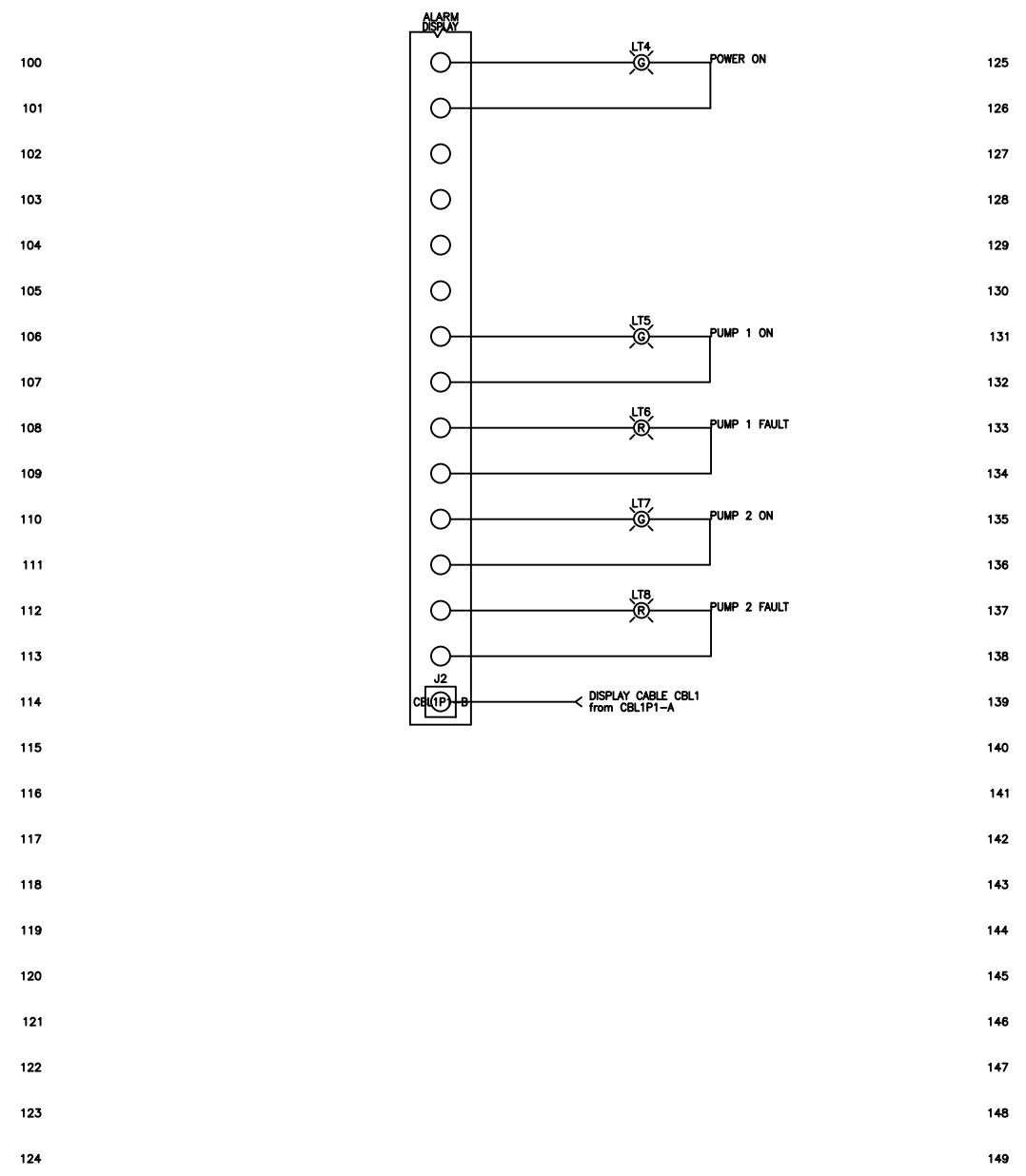

REVISIONS				
ZONE	REV	DESCRIPTION	DATE	APPROVED
	A	ADDITION OF OPTIONAL SEAL FAIL RELAY	1/17/15	
	B	UPDATED INSTRUCTIONS	5/25/17	
	C	REVISED CBS	9/21/17	
	D	UPDATED TERMINAL BLOCKS	11/13/17	
	E	UPDATED SEAL FAIL RELAY	2/28/18	
	F	Transformer Label X1 to XF	4/29/19	

FIELD WIRING CONNECTIONS

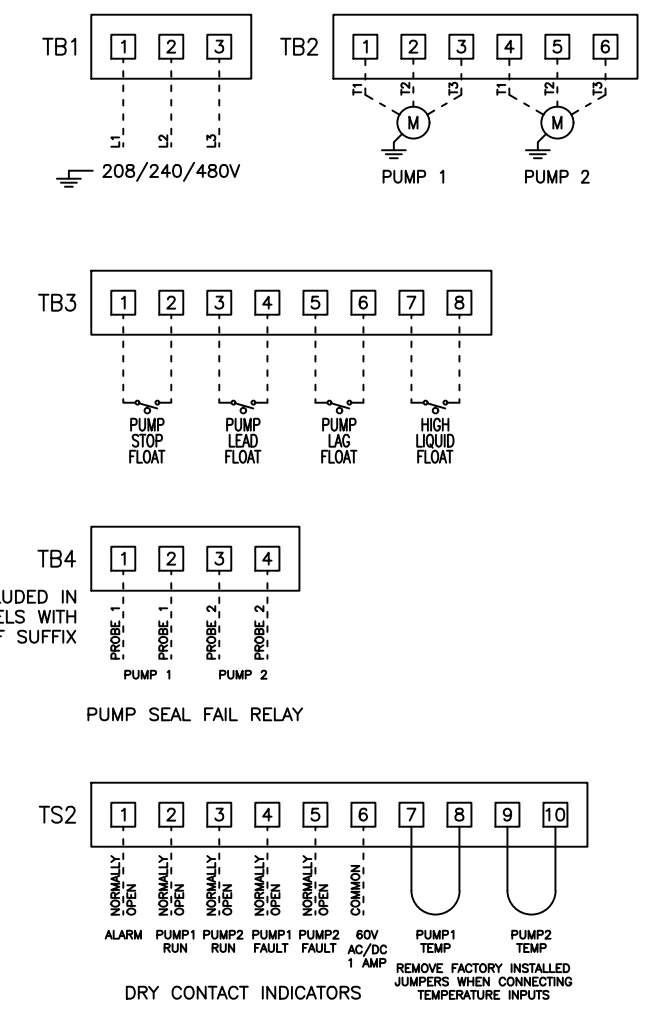

MULTITAP TRANSFORMER INSTRUCTIONS:

CONNECT FACTORY TAGGED WIRES TO APPROPRIATE TRANSFORMER VOLTAGE TAP. SEE BELOW FOR CONNECTIONS:

FOR 208V OPERATION, CONNECT TO FUSE INPUT HF & TO TRANSFORMER TAP H2

FOR 240V OPERATION, CONNECT TO FUSE INPUT HF & TO TRANSFORMER TAP H3

FOR 480V OPERATION, CONNECT TO FUSE INPUT HF & TO TRANSFORMER TAP H4

----- DASHED LINE INDICATES FIELD WIRING.

USE COPPER CONDUCTORS ONLY.

TEMPERATURE RATING OF CONDUCTORS IS TO BE 60°C (167°F).

BRANCH CIRCUIT PROTECTION SHALL BE PROVIDED BY THE INSTALLER. MUST BE SIZED ACCORDING TO PUMP/MOTOR MANUFACTURING SPECIFICATIONS.

VERIFY CORRECT OPERATION OF CONTROL PANEL AFTER INSTALLATION IS COMPLETE.

DRAWN BY: KJ		DATE: 1/8/15					
APPROVED BY:		DATE:					
THIS DRAWING CONTAINS PROPRIETARY INFORMATION AND SHALL NOT BE USED OR DISCLOSED WITHOUT PRIOR WRITTEN AUTHORIZATION.				TITLE: IS-WD3P-4-302X CONTROL SCHEMATIC			
				SIZE: B	DWG NO.: 1534	PART NO.: IS-WD3P-4-302X	REV: F
				SCALE: NONE		SHEET: 3 OF 3	