

OIL SMART® DISCONNECT PUMP CONTROLLER

BN	IM505
REV	1011

Designed for Use with Hydro Generation Units Oil Smart® Disconnect Pump Controller

In the event that the pump controller fails to deactivate the pump, the shut-down device will de-energize the pump controller, thus substantially preventing the hydro unit from being damaged by dry conditions. The redundant off feature provides added pump protection.

TECHNICAL DATA:

Operating Voltages and **Model #'s:**

MAHR1 120VAC 50/60 Hz. 16AMP 1HP NO PLUG

MAPR%120VAC 50/60 Hz. 1Ā Amp F HP PLUG

WITH DISCONNECT:

Model No.	HP	Volts
OSDGEÜÏ	0-1	120
OSDGEÚÓÚÏ	0-F	120

Oil Smart® pump controller with 20Ccord, bracket and 6" or 2.5" differential-ON & OFF SENSORS.

- Dimensions: 2.50" Wide x 6" High x 1.75" Deep plus 2.5" or 6" OFF sensor
- Magnetic Motor Controls UL508
- Listed Industrial Control Equipment
- Completely Encapsulated & Water Tight
- CE Certified
- Patent Pending
- **A solid-state sensing device that differentiates between water and oil**
- **Incorporates three level sense points, pump on, pump off, and system shut down for pump protection and prevents pumping oil and any hydrocarbons into the environment.**

WARRANTY:

• Oil Smart® Pump Switch, SEE Water® Inc. warrants that the See Water Oil Smart Pump Switch will be free from defects in material and workmanship for a period beginning as of the date of purchase for t@^^ (H) years. Replacement of the switch only at the sole discretion of See Water Inc. This warranty is valid only when the product is installed in strict compliance with the manufacturer's installation instructions. See Water Inc. will in no way be responsible for the reliability of any pump that is connected to or operates with SEEwater, Inc. products. See Water, Inc. will replace the switch when it is returned to See Water's factory, postage prepaid with proof of original purchase included.

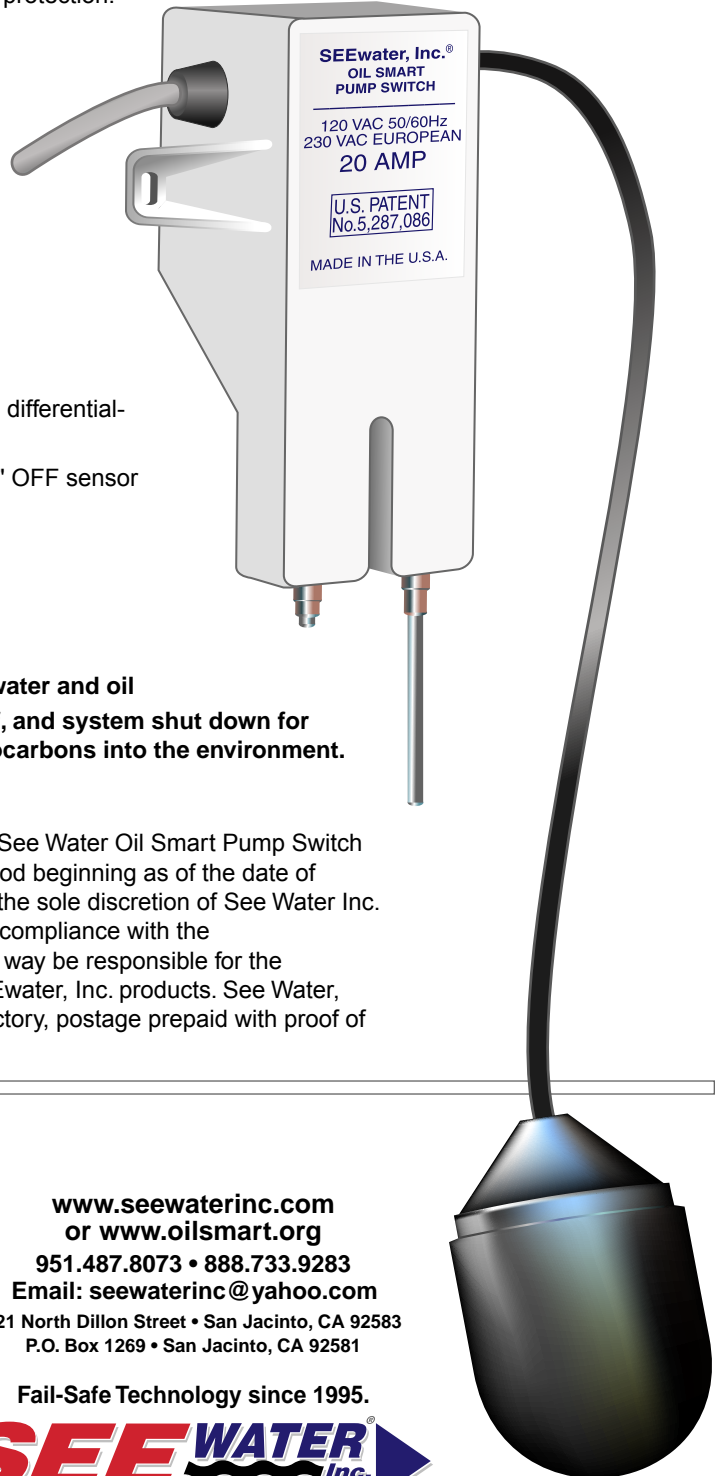

www.seewaterinc.com
 or www.oilsmart.org
 951.487.8073 • 888.733.9283
 Email: seewaterinc@yahoo.com
 121 North Dillon Street • San Jacinto, CA 92583
 P.O. Box 1269 • San Jacinto, CA 92581

Fail-Safe Technology since 1995.



HYDRO GENERATION OIL SMART® DISCONNECT PUMP CONTROLLER

OIL SMART® SWITCH AND PUMP INSTALLATION:

CAUTION: YOU MUST REMOVE ANY FLOAT SWITCH THAT IS CURRENTLY IN USE OR SUPPLIED BY PUMP MANUFACTURER. IF PUMP HAS MANUAL/AUTO SET, SWITCH TO MANUAL.

Installation of the **Oil Smart® water pump switch** allows you to comply with State and Federal regulations while reducing the risk of adverse publicity, fines and expensive cleanup costs. The **Oil Smart® water pump switch** prevents inadvertently pumping oil contaminated waste into the environment, improves the reliability of your electric system and provides a safe, dry work environment for your employees.

FUSING:

Follow the pump manufacturer's instructions. Do not exceed the Oil Smart® switch amp rating. **A portable device may not be attached to a permanent structure.**

THE INITIAL INSTALLATION:

should be in a clean environment, clear of mud and all metallic debris. The switch should be installed where the water intrusion will not directly contact or splash the switch body.

Mud and other **conductive** materials left on the body of the switch will hamper its operation. Effort must be taken to **clean the switch** prior to leaving initial installation.

CLEAN STRUCTURE:

requires minimum switch maintenance for a trouble-free operation. Install the switch so that on and off sensors clear any metallic material (earth, mud, concrete and all metals) by a minimum of 2".

SWITCH MAINTENANCE:

The white plastic case must be clean of any conductive materials (dirt, soap or rust). Clean with alcohol.

Operation:

When water comes in contact with the short (on) sensor, the pump will turn on. The pump will remain on until water clear the long (off) sensor. If oil comes in contact with the on sensor, the pump will not turn on; however the pump switch will activate and pump water from under the oil. Oil does not harm the system in anyway. The sensors can oscillate through oil and see water.

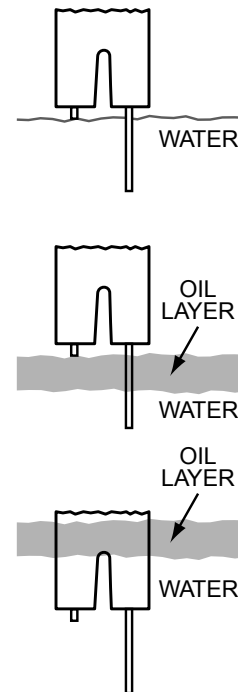

Using the Alligator Clamp

Alligator clamp enclosed, connect (tether) the float switch at a level that is in the "on" position. At least 2" below the "off" sensor, connect the alligator clamp on the float cable 3" from the float.

WIRING DIAGRAM

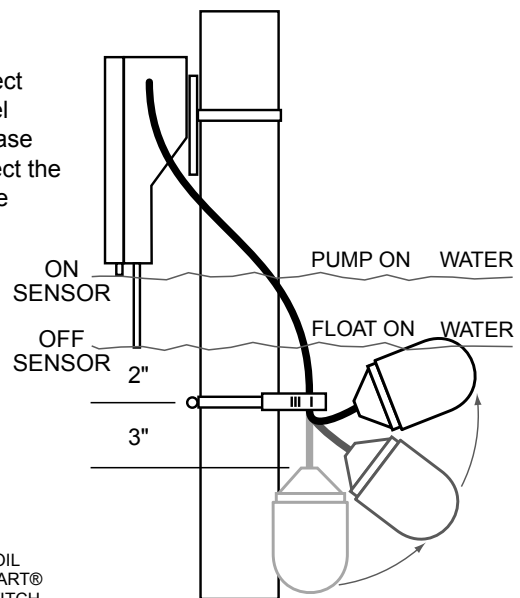
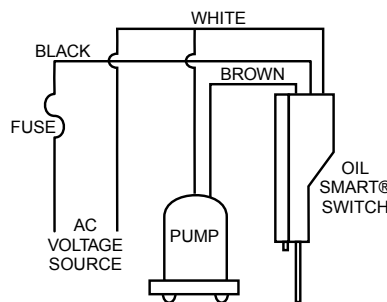

www.seewaterinc.com or www.oilsmart.org

951.487.8073 • 888.733.9283 • Email: seewaterinc@yahoo.com

121 North Dillon Street • San Jacinto, CA 92583

P.O. Box 1269 • San Jacinto, CA 92581

Printed in U.S.A.

Fail-Safe Technology since 1995.

SEE WATER Inc.
"OIL SMART" Water Pump Switches